

CAR SET UP

MUST DO'S

1. Derby car specs. American made, Full Size, Front or Rear Wheel Drive, Gas or Diesel – No Commercial Vehicles.
 - a. All Glass, chrome, pot metal handles, upholstery, headliners, floor mats and seat must be removed.
2. Must have a driver lap seat belt. Shoulder straps are optional
3. Driver's side door must be padded with suitable padding for driver protection
4. Stock gas tank must be removed from stock location.
5. Gas tank must be re-installed in the center where the back seat used to be.
6. All tanks and their installation are subject to official approval.
7. If vehicle is factory fuel-injected, with fuel pump inside gas tank, a master kill switch MUST be installed and readily and easily accessible to outside emergency personnel. The switch needs to be clearly identified. THIS COULD SAVE YOUR LIFE!
8. Batteries must be sealed or have anti-spill caps and all batteries must be covered with a suitable material driver protection.
9. Batteries must be securely attached in a battery holder and secured to the floor right side floor board.
10. Driver's door must have metal reinforcement not to exceed past driver's door compartment. For driver protection only.
11. Trunks must be empty. No spare tires or extra weight.
12. All cars must have a fire wall between the driver and engine compartment.
13. All gas lines must be routed in a safe manner with proper fittings and clamps.
14. Hoods must have at least one 8" hole in the center for fire extinguisher access.
15. All drivers' doors must be painted a contrasting color with word "STOP" or "STOP" sign painted on it....DO IT!
16. All cars must have a large number plate on top of the car with racing numbers on both sides of plate. Also recommended on the sides of the car.
17. Driver must have a racing type helmet, suitable eye protection. Long pants and long sleeve shirt. Gloves are optional. Fire suit recommended but not required.
18. Every pit must have a fire bottle readily accessible.

CAR SET UP

CAN DO'S

1. All threads or chain may be used to secure the hood; cannot be welded to the frame or through the frame, 4 maximum.
2. Bumpers can be chained. Chain size cannot exceed ¼". Subject to official approval.
3. Bumpers can be welded to the bumper brackets and brackets can be welded to the frame.
4. Rear bumpers can be welded to the trunk.
5. Shock absorber bumpers can be welded solid or removed and replaced with bumper brackets.
6. Bumpers can be trimmed.
7. Fenders can be trimmed for additional tire clearance not to exceed 8'.
8. Body can be removed and bolted solid to the frame.
9. Doors can be chained or welded. Weld straps over door seams not to exceed 1/16" thick and 3" wide.
10. Trunks can be welded solid. Welds only – **NO** back up plates.
11. Coil Springs can be tack welded.
12. Rear axles can have limited chains installed, but not tight.
13. Stock gas tank or metal boat tanks can be used.
14. Transmission cooling tanks can be used.
15. Dash boards can be removed and replaced with 3" OD Cowl bar.
16. Driver's door and front passenger door should be reinforced for driver protection.
17. Motor mounts can be solid.
18. Hard top models can be strapped from inside of door to roof top with 3" wide by 1/8th thick metal strap.

VIEW FROM REAR OF CAR

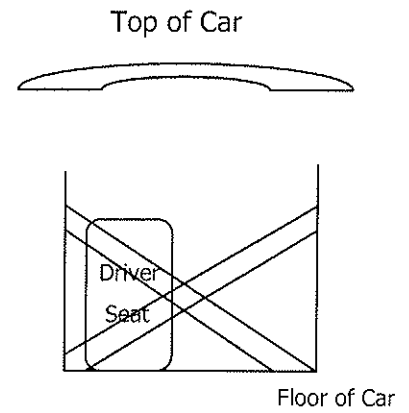
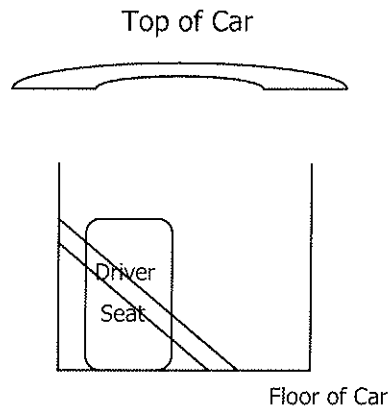
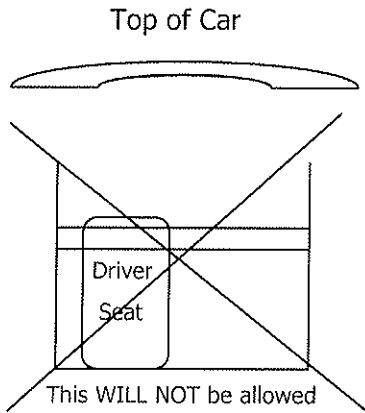

Any configuration above is acceptable. This is for driver protection only, not for the strength or durability of the car.

CAR SET UP

CANNOT DO'S

1. No Chrysler Imperials⁴73 or older – No Commercial Vehicles No Hearses, No Compact Vehicles.
2. No full cages.
3. No extra radiator cooling tanks. Radiator stays in stock location. No Anti-Freeze.
4. No hand held starting fluid.
- 5.
6. No added reinforcement to bumper or bumper brackets.
7. No reinforcing or welding hood to fenders. Weld on fender/hood seam only, level with top of fender.
8. No solid suspension.
9. No switching of suspension parts from original; i.e. coil to leaf springs.
10. No off-road or implement tires. No foam filled tires. All tires subject to approval. 8 ply rating max.
11. No reinforcement inside the car other than as described in the accompanying diagram
12. No reinforcement pipe larger than 3" O.D.
13. No reinforcement of any suspension parts, steering components including wheels, tie rods, A-frames, etc.
14. No reinforcement of any type on the outside of the car.
15. Body cannot be welded to frame.
16. No additional reinforcement of frames, fenders, radiator core or core support.
17. No reinforcement of tire rims.
18. No full windshield screens
19. No side window bars. Hard tops accepted; 3" strap max top to bottom of window.
20. No after-market fuel pumps.
21. No trailer hitches or trailer hitch assemblies allowed.

Winning car may be inspected following race.

ACTIONS WHICH COULD RESULT IN DISQUALIFICATION
(Decision will be made by Officials)

1. Intentional hitting on the driver's door (left to the discretion of the judges.)
2. Sand-bagging.....failure to drive aggressively.
3. Failure to drive in a heat race.
4. Leaving your vehicle – except in case of fire or injury or at the request of officials.
5. Sitting still for any reason for two (2) minutes or more. If you are blocked, the driver must make attempts to unblock himself. Driver must involve himself in the mainstream action of the main event within two (2) minutes. (This is left to the discretion of the officials.)
6. Allowing any work or maintenance to be done to your vehicle during pauses of racing while in the race arena.
7. Allowing your pit crew in the race arena during races.
8. Being under the influence of alcoholic beverages and/or any illegal substance while participating in the program on race night.
9. Failure to allow the car to be inspected following the race if requested by officials.
10. The driver is responsible for the conduct of himself, his pit crew and spouse as well as friends. Any display of violence, profanity, or unsportsmanlike conduct towards other drivers, fans, officials or volunteers will result in immediate disqualification or expulsion from the racing area/pits.
11. Any obscenities or obscene gestures of any type (i.e. mooning, nudity, etc.) will result in immediate disqualification

NOTE: Any car smoking in excess that becomes a hazard to other drivers or is unpleasant to spectators will be black-flagged.

WINNER WILL BE DECIDED BY ONE OF MORE OF THE FOLLOWING:

1. The last car to strike the other care that is still running.
2. The last car running will have to move forward or backward at least six (6) inches.
3. JUDGES DECISIONS ARE FINAL!!

NOTE: In the case of the last two cars, it is not mandatory for the trapping driver to free the trapped car in order for him to move. The trapping driver will be declared the winner.